

# Chlor NoMore IONIZER

FOR ABOVEGROUND AND INGROUND POOLS





**DO NOT CONNECT POWER TO YOUR  
Chlor NoMore Ionizer UNTIL YOU HAVE READ THESE INSTRUCTIONS  
“IMPORTANT SAFETY INSTRUCTIONS”**

**1. PLEASE READ AND FOLLOW ALL INSTRUCTIONS**

**2. \*\*\*WARNING\*\*\***

**RISK OF INJURY**

- Never permit children to operate this product

**RISK OF ELECTRICAL SHOCK & HAZARD:**

- Connect transformer only to a proper-sized grounding type receptacle protected by a Ground-Fault-Circuit-Interrupter (GFCI) Contact a qualified electrician if you cannot verify that the receptacle is protected by a GFCI
- **DO NOT** remove transformer power supply cord grounding prong. Doing so could result in serious injury or death
- **DO NOT** bury the electrical cord. Place cord out of the way of lawn mowers, hedge trimmers and other electrical equipment
- Replace a damaged electrical cord immediately
- **DO NOT** use an extension cord to connect the transformer to an electrical supply. Provide a properly located outlet.

**3. SAVE THESE INSTRUCTIONS**

## Chlor NoMore IONIZER REPLACEMENT CHAMBER

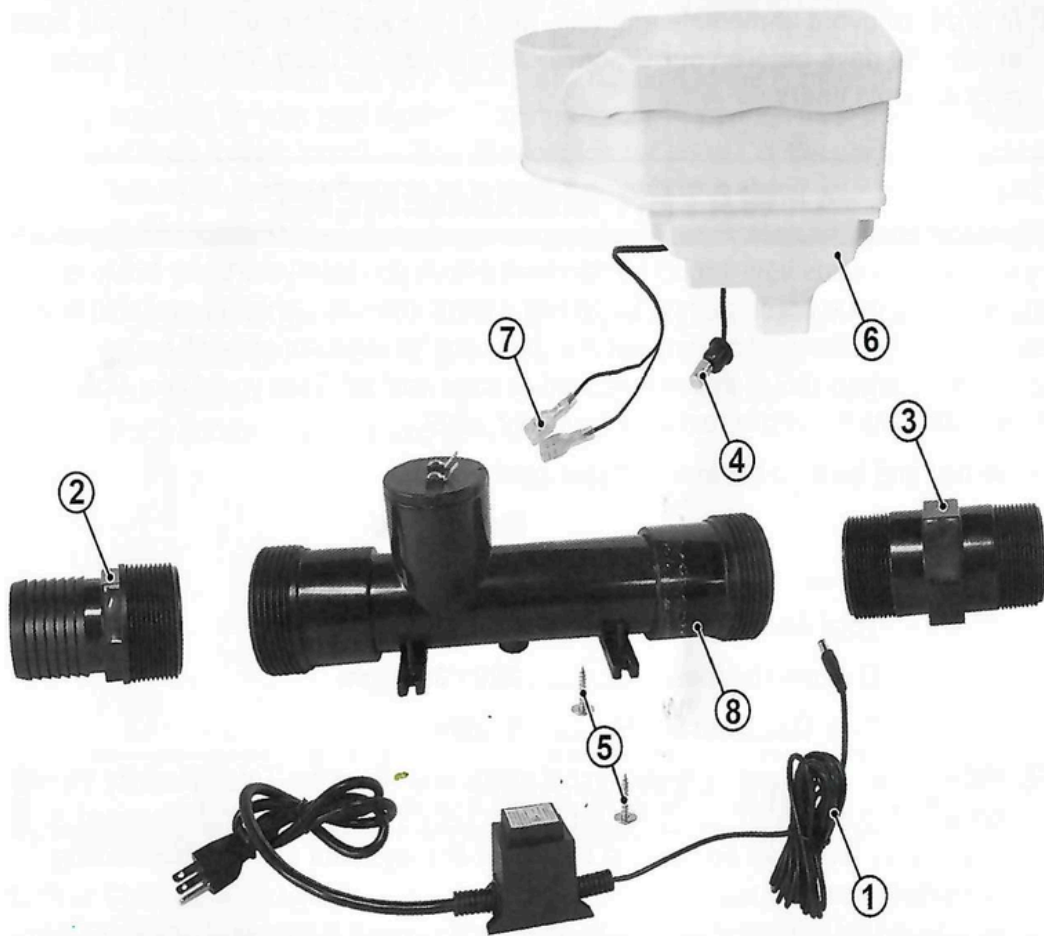

### TO REMOVE THE OLD CELL

1. Shut down the pool filtration system (shut down the pump), turn off the power and pull out the power adapter (1)
2. Unscrew (2) and (3) to remove (8) from the whole system
3. Pull out the temperature sensor (4)
4. Remove the two self tapping screws (5) with a fillips screwdriver
5. Remove the control box (6), pull out the terminal (7) so the cell (8) is now totally removed

### TO INSTALL A NEW CELL

1. Plug the terminal (7) into the new cell (8)
2. Attach the control box (6) to the new cell (8) using the 2 self tapping screws (5)
3. Plug in the temperature sensor (4)
4. Screw (2) and (3) in the new (8)
5. Plug in the power adapter (1)
6. Turn on the whole pool filtration system

## GETTING STARTED

**NOTE:** In order to avoid immediate staining, make sure any Marcite Finish pools cure at least 90 days before your Chlor NoMore Ionizer is used. This is not necessary on vinyl liners.

## WATER MANAGEMENT

1. If your water contains iron, it must be removed before you start your Chlor NoMore Ionizer. This can be accomplished by adding a metal remover, which is available from your pool dealer. It should be circulated in the water for approximately 48 hours. Your filter's system should then be cleaned or back washed. Turn your Chlor NoMore Ionizer "Off" until the iron is removed from your water.
2. Please test and balance the levels of your pool water.

	<u>Ideal Range</u>
pH .....	7.2 - 7.8
Total Alkalinity.....	80 - 140 ppm
Calcium Hardness.....	200 - 350 ppm
Total Dissolved Solids .....	1,000+

**NOTE:** Balance your calcium hardness first, if necessary. Then the Total Alkalinity should be adjusted before adjusting the pH. \*More details on the chemicals required to adjust your levels will be found in the Water Management and Troubleshooting Pamphlet provided.

**NOTE:** Stabilizer is not needed and may at high levels cause purple stain with high levels of ions in the water.

3. If the Total Dissolved Solids (TDS) in the water is less than 1,000 ppm, it will be difficult to build up an ion residual. The TDS can be raised by adding sodium chloride (pure salt) or swimming pool salt to the water. One pound (1 lb.) of sodium chloride will raise the TDS by 12 ppm in 10,000 gallons of water.
4. Shock your pool water with one pound (1 lb.) of Green Out per 10,000 gallons upon start-up. You must maintain a chlorine residual of 1.0 to 3.0 ppm in your pool water for 2 to 3 days (the time generally required to reach the adequate ion residual level in your pool). Chlorine levels can be maintained with slow dissolving chlorine tablets (read manufacturer's instructions for proper use). It is only necessary to maintain a chlorine residual until your ion residual reaches 0.3 to 0.5 ppm.
5. Your Filtration System should be in operation through the water balancing process. The Chlor NoMore Ionizer will activate the unit automatically once it has power and water flow is detected. At this point in time, adjust your Level Control to three (the "Active" light signifies operation). We recommend continuous water circulation or filter operation to speed the residual building process.

**\* SET CONTROL LEVEL TO LOWER SETTING IF RED CHAMBER LIGHT COMES ON.**

**NOTE:** It is important to check your ion level daily when starting up. It may only take a few days to build the residual with ideal conditions.

6. Check the ion residual daily until it has reached between 0.3 - 0.5 ppm. This should take approximately 2 - 3 days once the TDS level reaches 1,000 ppm. Once the recommended ion residual has been reached, you will need to carefully monitor the level setting on the Chlor NoMore Ionizer. Each pool has its own personality based upon usage and environment. Set your daily pump run time to the number of hours as recommended by your pool dealer. Continue to check your ion level every second day. If it continues to rise, turn the Chlor NoMore Ionizer Level Control down. If it starts to drop below 0.3, turn the Chlor NoMore Ionizer Control up. Once your ions residual has stabilized between 0.3 - 0.5 ppm, you can revert to testing your water on a weekly basis. It is no longer necessary to maintain a chlorine residual.

**NOTE:** Adjustment to your Chlor NoMore Ionizer Level Control will increase or decrease the residual level in your pool in conjunction with the length of your filtration cycle. For a longer filtration cycle, lower your Level Control. For a shorter cycle, turn up your Level Control.

## WATER TESTING AND OXIDIZING

1. Your Chlor NoMore Ionizer is introducing ions into your pool water which maintains water quality. However, it cannot remove the dead organisms and bather wastes which accumulate in the pool water. This is done by oxidizing or shocking. Your water balance is also very important and these parameters should be checked and adjusted, if required, on a weekly basis. Be sure that your pump is run for a few hours after you balance and oxidize your water.

2. A maintenance calendar has been included to reference for your convenience.

**NOTE:** If your pool is heavily used and the temperature becomes very hot or if you get a severe rain storm, you may have to oxidize more frequently. The first signs of a need to oxidize are the water losing its sparkle and/or an oily film developing on the surface of the water.

**NOTE:** If the ion residual gets excessively high, turn the Chlor NoMore Ionizer setting on your Chlor NoMore Ionizer to "0" immediately. Ensure that the water balance parameters are in check and allow the ions residual to come down on its own.

**NOTE:** The electrode bars are eroding while the Chlor NoMore Ionizer is used. Once you achieve the desired level and level control setting, over time you will need to increase that setting slightly to maintain that same ion level. Eventually you will have to set the control at "Maximum" and, once the bars have eroded to the point that they are no longer effective, your "Chamber" indicator will come on. At that point, you will have to change your Chlor NoMore Ionizer Chamber, which is recommended after one swimming season.

## Chlor NoMore IONIZER MAINTENANCE CALENDAR

### EXAMPLE OF MONTHLY POOL CARE

Monday	Tuesday	Wednesday	Thursday	Friday	Saturday	Sunday
1	2	3 Test Pool Water and Balance levels	4	5	6	7 Add 1 Lb. of Green Out Pool Shock per 10,000 gallons
8	9	10 Test Pool Water and Balance levels	11	12	13	14 Add 1 Lb. of Green Out Pool Shock per 10,000 gallons
15	16	17 Test Pool Water and Balance levels	18	19	20	21 Add 1 Lb. of Green Out Pool Shock per 10,000 gallons
22	23	24 Test Pool Water and Balance levels	25	26	27	28 Add 1 Lb. of Green Out Pool Shock per 10,000 gallons

## **Chlor NoMore IONIZER INSTALLATION**

**Note:** In order to avoid immediate staining, make sure any Marcite Finish pools cure at least 90 days before your Chlor NoMore Ionizer is used. Only use salt specifically made for use in swimming pools.

- Electrical Hook-up

### **CAUTION:**

- Do not connect power to your Chlor NoMore Ionizer until you have followed the System Installation Instructions.
  - Alteration of any electrical cord will render the warranty null and void.
  - Ensure that your electrical hook-up conforms with all local and national electrical codes.
- Your 120 volt Chlor NoMore Ionizer must be plugged directly into a properly grounded, GFCI protected receptacle with the cord provided.

**\*\*\*Please Reference Safety Instructions Before Proceeding!\*\*\***

If a GFCI protected outlet has been installed, you are now prepared to install your Chlor NoMore Ionizer.

**WARNING:** If your system includes a gas heater or Heat pump, be sure to install your Chlor NoMore Ionizer at least 18" from the heater unit.

## **SYSTEM INSTALLATION**

1. Turn your pool filtration system off. Plug both the water suction and return fittings on your pool to prevent any water loss during system installation.
2. Disconnect the water return hose from your filter unit and remove the connecting threaded fitting from your filter. Apply Teflon tape to the fitting and re-install it into the female pipe thread end of your chamber.
3. Apply Teflon tape to both ends of the connector fitting included with your system. Carefully thread it into your filter return port (DO NOT OVER-TIGHTEN).
4. Thread the other end of the connector fitting into the return side of the filter tank.
5. Open both your suction and return lines to your filter system and inspect for any water leaks. Turn your filter system on and connect power to your Chlor NoMore Ionizer.

## SYSTEM FEATURES

There are two(2) Indicator lights located on the front panel of the Chlor NoMore Ionizer.

- “Active”- indicates the unit is attached to a live power source, and the electrodes are receiving power.
- “Chamber”- indicates the electrodes are not producing and that it is time to replace your Electrode Chamber.

Your “Level Control” will adjust the rate at which ions are dispensed into pool water. Follow the instructions under the “Getting Started” sheet, paragraphs 4 - 6, to use this control properly.

### TEMPERATURE DISPLAY

The Temperature Display is provided to allow you to know the approximate temperature of the water in your swimming pool with a glance from a distance, provided your filtration system is operating at the time.

After installation if your System faces the wrong direction to see the display, it can be reversed by simply removing the four (4) mounting screws that secure the Transformer Module to the Electrode Chamber and turning it around. If you do this, just be careful not to damage the temperature sensor cable when you reattach the Chamber to the Module. (See “Replacing Your Electrode Chamber” for an illustration.)



# Chlor NoMore IONIZER FEATURES

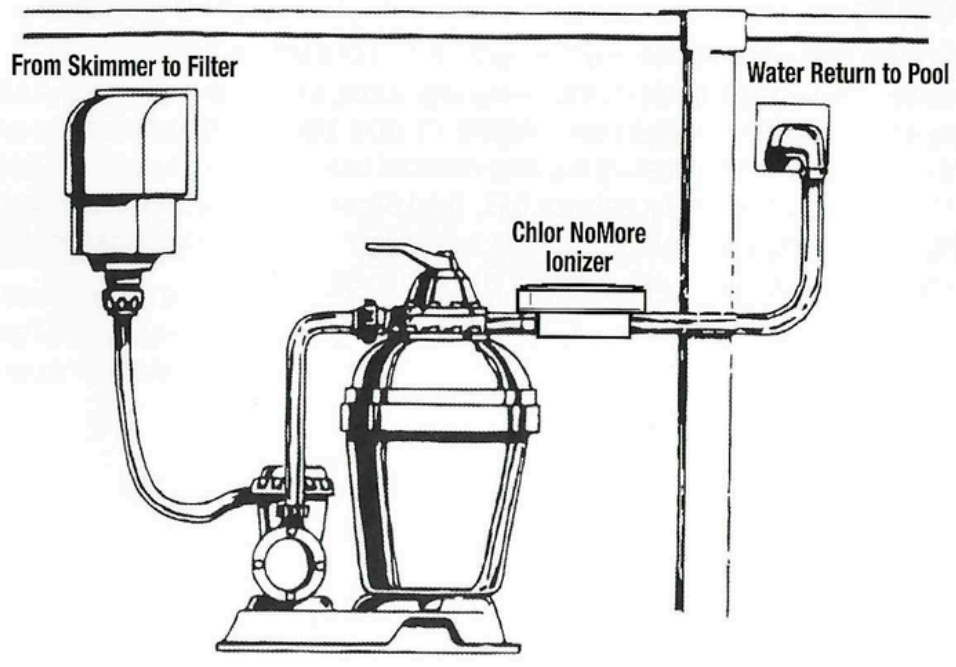
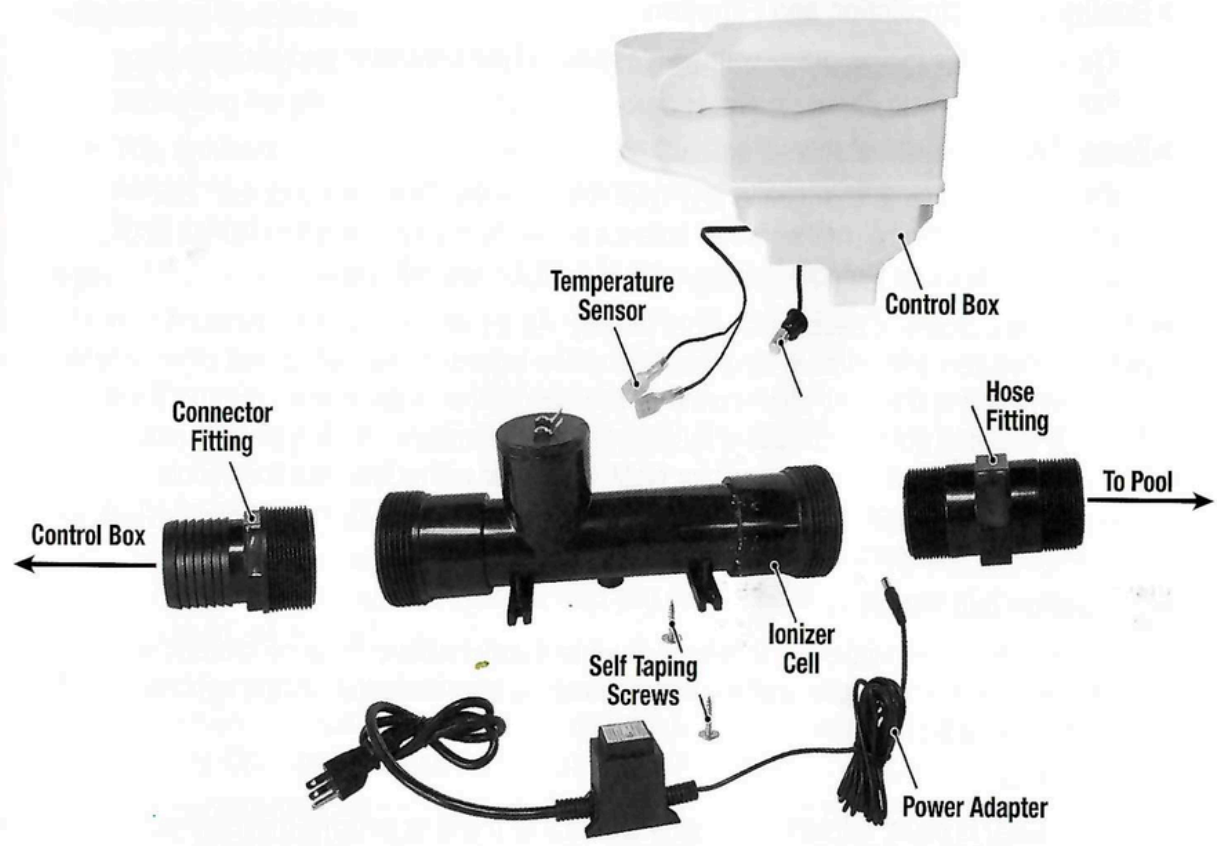

## A FRESH LOOK AT THE BASICS

To have pure water in your pool, you need to manage:

- **Quality Water Circulation and Filtration**

The continuous movement of water necessary to filter out debris and circulate in oxidizers.

- **Water Balance and Stability**

Water is sensitive to changes in pH, Total Alkalinity and Calcium Hardness. Your Chlor NoMore Ionizer makes water balance easier to maintain. Unlike chlorine and bromine, the Chlor NoMore Ionizer, natural minerals are pH neutral.

- These three processes affect each other directly. As a result, you need a maintenance program that keeps them all in balance. One of the biggest complaints about chlorine and other chemicals is that they often create a “see-saw” effect in the water’s pH and Total Alkalinity that can only be corrected by adding more chemicals, making stability and balance difficult to maintain. Your Chlor NoMore Ionizer will reduce this fluctuation. Your Chlor NoMore Ionizer maintains water the natural way with ions. Without affecting the balance of important pool water properties.

- **Circulation and Filtration**

Circulation is essential since it helps ensure that water will not become a breeding ground for bacteria, algae and viruses. Filtration is also essential since it removes debris from water.

- **Purification**

Pure water is clear, refreshing, healthy and free of micro-organisms that dirty your pool and cause disease. Maintaining pure water requires the removal of harmful micro-organisms through disinfection and oxidation.

- **Disinfecting**

The most common chemical used in the treatment of swimming pool water is chlorine. While chlorine kills harmful living organisms, it is so powerful it can create a very uncomfortable swimming environment. Chlorine can also be unstable. As a result, chlorine-treated water generally requires constant monitoring and frequent chemical additions which affect water balance (pH, Total Alkalinity and Calcium Hardness). This need for regular chemical adjustments and increased pool maintenance can reduce the joy your pool was originally intended to generate.

- **Oxidation**

Oxidation is needed to eliminate dead algae, dead bacteria and organic wastes from your pool. Be sure to follow the manufacturer's instructions to insure that adequate oxidation occurs.

- **Balancing Your Water**

Beyond quality filtration, disinfection and oxidation, water balance is maintained by controlling the pH, Total Alkalinity and Calcium Hardness levels of your pool water.

The ideal ranges for pH, Total Alkalinity and Calcium Hardness differ with local water conditions. Also, water balance must be monitored regularly since it can be disrupted by almost anything.

- **pH** The pH refers to water's acidity (basicity). An improper pH level can damage your pool's surface, plumbing and equipment. For instance, etching of the pool surface or corrosion of metal parts in the pump and plumbing are signs that water is too acidic (pH is too low). Alternatively, scale on the pool surface, cloudy water and fouled equipment are signs of water that is too basic (pH is too high). The recommended level of pH is between 7.2 and 7.6.

- **How to correct pH.** If pH is too low, add soda ash (following manufacturer's instructions to reach the ideal range). If pH is too high, add dry acid (following manufacturer's instructions). An Acid Demand Test will help you determine the amounts of dry acid needed to adjust your pH.

- **Calcium Hardness.** All water naturally seeks moderate hardness levels. While some forms of chlorine actually make water harder, the natural process of Smart Ionizer has no effect on Calcium Hardness, so it helps maintain balance.

The recommended minimum level of Calcium Hardness is 200-350 parts per million (ppm). If your water hardness is too low, the water will seek sources of calcium. In plaster pools, water will actually start dissolving the plaster, bringing a rough feel to the pool surface (called plaster "etching"). It will also become very corrosive to the pool equipment. On the other hand, excessive hardness may create hard, rough, discolored deposits on the pool surface and inside pool equipment (called "scale").

Controlling scale formation requires tighter control of Total Alkalinity and pH at the lower end of their ideal ranges. This is particularly important if Calcium Hardness rises above 400 ppm.

How to Correct Calcium Hardness. Increasing Calcium Hardness is easy: add hardness ~ increaser such as calcium chloride (following manufacturer's instructions to reach the ideal range). However, removing hardness is more difficult. You may have to partially drain your pool and then refill it with new water containing a lower calcium hardness level.

- **Total Alkalinity.** Total Alkalinity is the water's "buffer capacity". Properly balanced Total Alkalinity helps the pH level remain stable, and prevents scale deposits from forming on pool surfaces. Low Total Alkalinity means that water has too little buffering capacity, which results in constantly fluctuating pH readings. This can damage equipment and pool surfaces. High Total Alkalinity is indicated by:

- pH is difficult to adjust
- Cloudy water
- Potential for scaling

The ideal range of Total Alkalinity is 80-120 ppm.

- **How to correct Total Alkalinity.** When Total Alkalinity is too low, an alkalinity increaser (following manufacturers instructions to reach the ideal level) will return it to the recommended level. Total Alkalinity that is too high may be more difficult to adjust and may require a large amount of acid to bring it down.

## **TROUBLESHOOTING FOR A PROBLEM WATER**

The Temperature Display should be lit anytime your unit is attached to the appropriate power source. The "Active" indicator should be lit anytime your unit is plugged-in and water is flowing through it. If it is not lit:

1. Make sure the power is on. The receptacle should be ground-fault-protected. Check the status of the ground-fault-protector to see if it is tripped. If tripped, follow your ground-fault operating instructions to reset. If it continues to trip, contact your local pool dealer for assistance. If the GFCI is not tripped, make sure the circuit breaker in your main breaker panel is on.
2. Make sure the power source is correct. Compare it to the electrical rating on the top of the transformer module.
3. Make sure the pump is operating and water is flowing through the unit. The System senses water flow and without it this light will not come on.
4. If the power is on, the GFCI is not tripped, and you have good water flow, contact your local pool Chor NoMore Ionizer dealer for assistance.

The "Chamber" indicator should only come on if your bars are no longer able to put ions into your pool and your Level Control is set at "Maximum". If it is not lit, your system should be operating normally.

### **If it is lit:**

1. Check the connection to the Chamber from the Transformer Module. Reconnect if necessary.
2. If the connection between the Chamber and Transformer Module is good and the light is still on, then it is time to replace your Chlor NoMore Ionizer Chamber.

**NOTE:** The electrode bars are eroding while the Chlor NoMore Ionizer is used. Once you achieve the desired control setting, over time you will need to increase that setting slightly to maintain that same level. Eventually you will have to set the control at "Maximum" and, once the bars have eroded to the point that they are no longer effective, your "Chamber" indicator will come on. At that point, you will have to change your Chlor NoMore Ionizer Chamber.

## **1 YEAR HASSLE FREE WARRANTY**

This warranty extends to the original purchaser only and commences on the date of original retail purchase, regardless of date of installation. Accordingly, this warranty is not transferable to subsequent purchasers.

If your Chlor NoMore Ionizer ceases to operate within the warranty period, it will be repaired or exchanged by your local Chlor NoMore Ionizer Dealer, at no charge. This warranty does not cover any Chlor NoMore Ionizer which has been subject to misuse, neglect, negligence, or accident, or that has been operated in any way contrary to the operating instructions as specified in the instruction-manual. This warranty does not apply to any damage that is a result of improper maintenance or to any Chlor NoMore Ionizer which has not been installed as specified in the owner's manual. This warranty also does not cover any Chlor NoMore Ionizer that has been altered or modified.

**IN ORDER FOR THIS WARRANTY TO BE EFFECTIVE, YOUR INFORMATION MUST BE REGISTERED WITH YOUR LOCAL Chlor NoMore Ionizer DEALER.**

To obtain warranty service, the Chlor NoMore Ionizer must be returned, within the warranty period to your local Dealer. The expense of removing, reinstalling and returning the System is the responsibility of the owner, THE COMPANY'S responsibility with respect to warranty claims is limited to exchanging or repairing the System and shipping charges related to its return to the owner. No claim of breach of warranty shall be cause for cancellation or rescission of the contract of sale of any Chlor NoMore Ionizer.

THE COMPANY reserves the right to change or improve the design of any Chlor NoMore Ionizer without obligation to modify any System previously manufactured.

All implied warranties, including merchantability and fitness for a particular purpose are disclaimed in their entirety after expiration of the warranty period with respect to parts and design.

THE COMPANY's obligation under this warranty is strictly and exclusively limited to the exchange of defective Chlor NoMore Ionizer and THE COMPANY does not assume or authorize anyone to assume for it, any other obligation.

THE COMPANY's assumes no responsibility for incidental, consequential or other damages including, but not limited to, transportation or shipping expenses, telephone charges, rental of a like product during the time warranty service is being performed, travel, loss or damage to personal property, loss of revenue, loss of use, loss of time or inconvenience.

Some states do not allow the exclusion or limitation of incidental, consequential damages, so the above limitations and exclusions may not apply to you.